

# HOLLOWTECH II crankset assembly

## Installation of the Crankset

Follow the procedure in the figure.

- 1,2 Use the special tool TL-FC32 to install the right adapter (counterclockwise thread) and the left adapter (clockwise thread).  
Tightening torque : 35 - 50 N · m {305 - 435 in. lbs.}

Note: Face and chase the BB shell. This will ensure that the bearings are properly aligned and will prevent excessive bearing wear and creaking. (Contact the frame manufacturer for special instructions and/or Park Tool Co.)

- 3 Insert the right crank unit.
- 4 Set section A of the left crank into the axle of the right crank unit where the groove is wide. (Insert a spacer when installing the FC-6603 left crank unit.)
- 5 Use the TL-FC16 to tighten the cap.  
Tightening torque : 0.7 - 1.5 N · m {6 - 13 in. lbs.}
- 6 Tighten the bolt of the left crank.  
Note : Each of the bolts should be evenly and equally tightened to 10 - 15 N · m {88 - 132 in. lbs.}

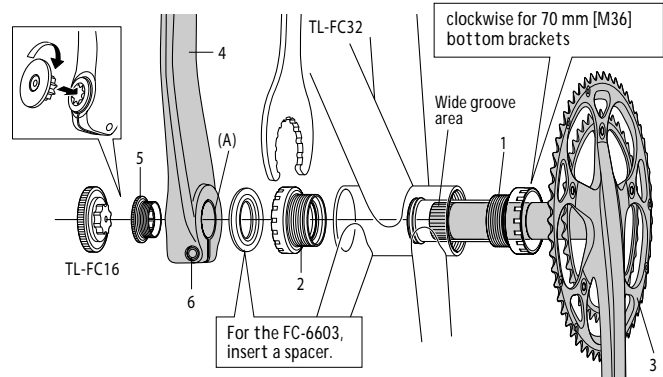

## Spacer installation method (MTB)

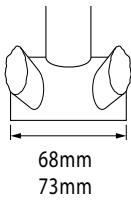

FC-M960/FC-M800/FC-M760  
FC-M600/FC-M580

Band Type	Bracket Type
68mm 	68mm 
73mm 	73mm 

Spacer
(A) 2.5mm
(B) 1.8mm
(C) 0.7mm

Spacer
(D) 2.5mm Come with front derailleur

FC-M761/FC-M581

Band Type	Chaincase Support Type *	E-Type Bracket
68mm 	68mm 	68mm 
73mm 	73mm 	73mm 

\* Chaincase support type:  
Commonly used in Europe, this set-up is used when combining a chaincase that uses a support arm that mounts under the bottom bracket cup.

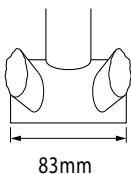

FC-M805

Band Type	Bracket Type
83mm 	83mm 